



WAVE XL 46" MONITOR

The Wave Monitors are a series of well-designed, rugged LED displays. Our monitors are built following a modular approach, making them suitable for OEM as well as Private Label versions.

Our displays can be flush mounted with a panel mounting kit or standing with hinge mounted to table. It can even be mounted with hinge hanging from the roof (no HMI). Sunshade and Vesa adaptor are also available.

All our monitors are provided with AC/DC inputs and can even be used as a part of a UPS system. For improved performance and reliability backlight is based on LED technology.



TECHNICAL SPECIFICATIONS XL 46" WAVE MONITOR

MATCHING STANDARDS	IEC 60945, IACS E10. Designed to comply with MIL-STD-810F & MIL-STD-901D. Reports available on request.
DISPLAY SIZE	46.0" - 1168,4 mm, active area 1018,08 (Hor) x 572,67 (V) mm
TOUCH	10 point infrared multitouch
OPERATING SYSTEM	Windows7/ 8/ Vista/ XP/ Mac/ Linux
TOUCH ACCURACY	± 2 mm
TOUCH RESPONSE TIME	6-15 ms
TOUCH INTERFACE	USB
OVERALL DIMENSIONS	1175,0 (W) x 722,61 (H) x 69,0 (D) mm - console mounting
NET/GROSS WEIGHT	32 Kg excl tilt unit
RESOLUTION	Max 1920 x 1080 pixels (HDTV)
SYNCHRONISATION	Separate/Composite, 15-100 kHz (H), 30-60 Hz (V)
RESPONSE TIME	6,5 ms
CONTRAST RATIO	4000:1 (typ)
DOT PITCH	0.17675 (H) x 0.53025 (V) mm
LIGHT INTENSITY	700 cd/m2 (typ)
NUMBERS OF COLOURS	16.7 Millions depending on graphics card
VIEWING ANGLE	±89°
CONTROLS KNOBS	Lock, +, -, (Brilliance), Set, Menu and Power
INDICATORS	Power indicator, AC or DC
SUPPLY VOLTAGE	90-264 VAC, 24 VDC -20/+30%
POWER CONSUMPTION	App.90 W (AC) / 90 W (DC)
COLOURS	Cabinet Black RAL 9005 fine structure.
ENCLOSURE PROTECTION	IP 42
GLASS TYPE	Tempered, antiglare coated 5mm
CONTROL INPUT	RS 232 D-SUB 9 pin female
OPERATING/STORAGE TEMP.	-15/+55° C. +5/131° F (IEC 60945) / -20/+60° C. -4/140° F
INPUT	DVI-I (Analogue and Digital), VGA, Composite video, S-Video, AC power IEC Inlet & DC screw terminal
BACKLIGHT LIFE	Typ. 50.000 hours
DIMMING RANGE	0-100%
CONFIGURATION-0001 TABLE MOUNTED	
CONFIGURATION-1001 TABLE MOUNTED WITH TILT UNIT	
CONFIGURATION-2001 PANEL MOUNTED	
CONFIGURATION-3001 PANEL MOUNTED WITH HMI	



WAVE XL 46" MONITOR

WAVE XL 46" TABLE MOUNTED: WA460-01.MON.01-0001

Note: All dimensions are in mm. For panel cutout: see page 6.

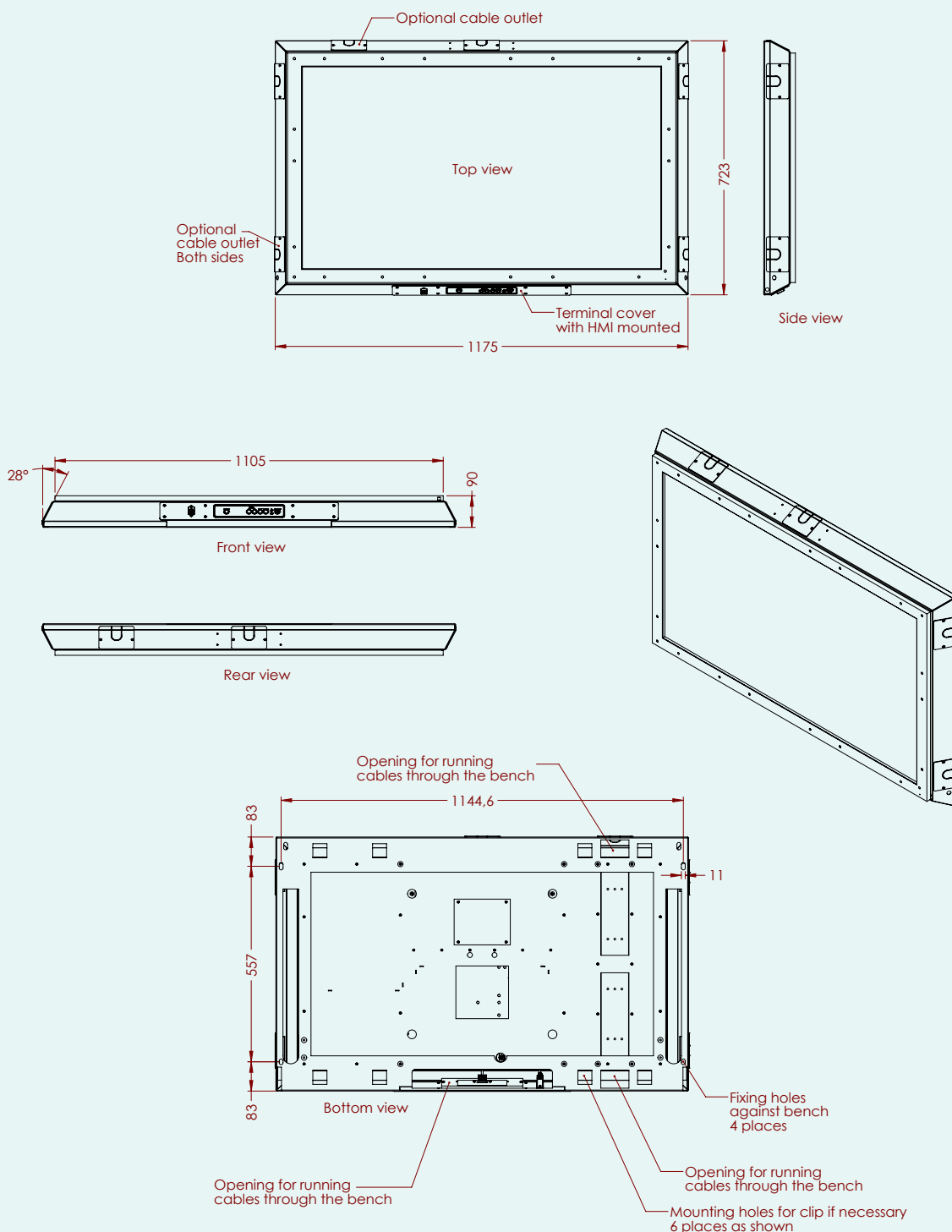

WA460-DS-REV2.0-01.2015

ALTRONICS
CS 69024, F-69811 Tassin

Tel : +33 (0) 472 370 470
 ALTRONICS

info@altronics.fr
www.altronics.fr





WAVE XL 46" MONITOR

WAVE XL 46" TABLE MOUNTED WITH TILT UNIT: WA460-01.MON.01-1001 INCLUDES WA460-01.TIL.01-0001

Note: All dimensions are in mm.

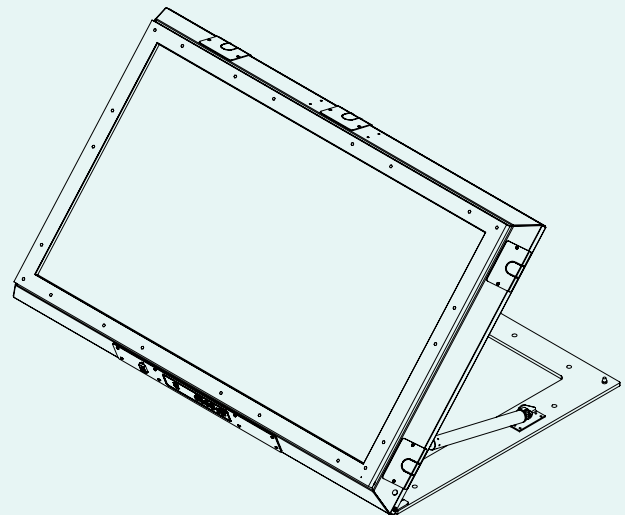
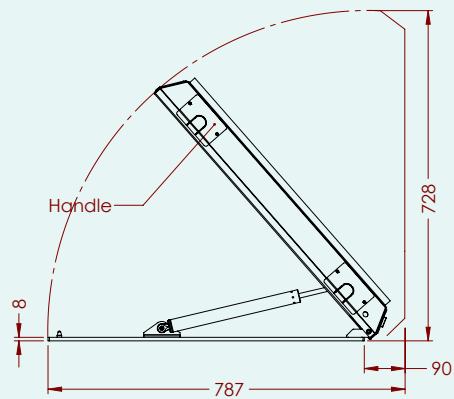
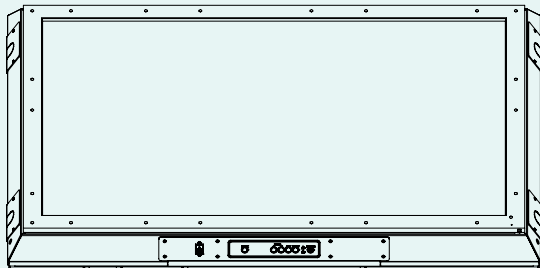

Note: This component is under construction. Please contact our Sales Department for further information.



WAVE XL 46" MONITOR

WAVE XL 46" PANEL MOUNTED: WA460-01.MON.01-2001

Note: All dimensions are in mm. For panel cutout: see page 6.

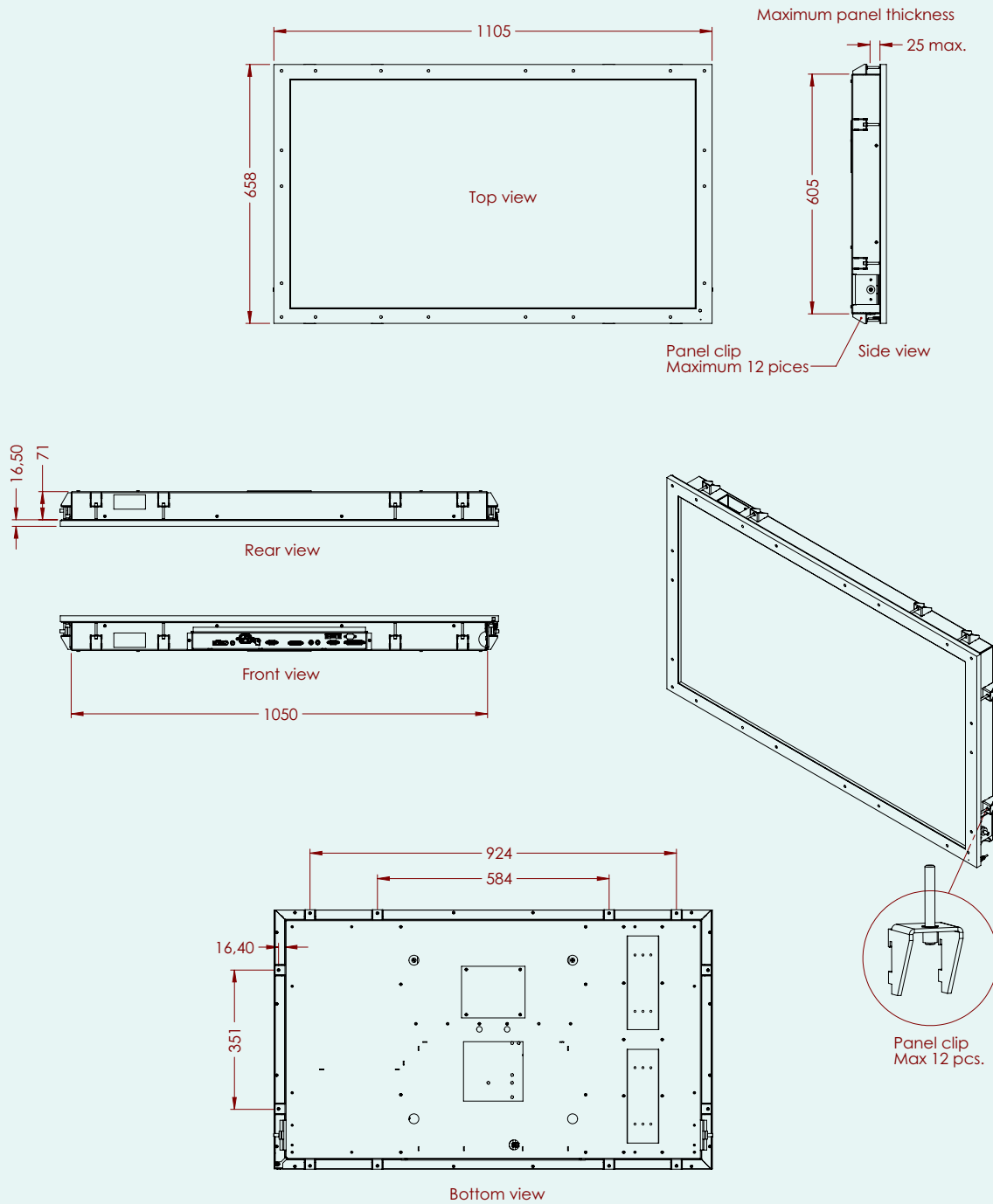

WA460-DS-REV2.0-01.2015

ALTRONICS
CS 69024, F-69811 Tassin

Tel : +33 (0) 472 370 470
 ALTRONICS

info@altronics.fr
www.altronics.fr





WAVE XL 46" MONITOR

WAVE XL 46" PANEL MOUNTED WITH HMI: WA460-01.MON.01-3001

Note: All dimensions are in mm.

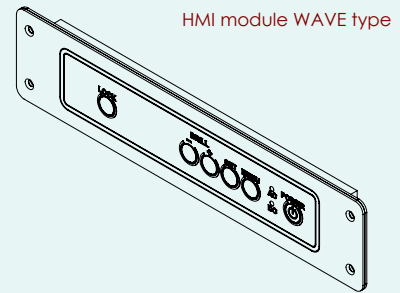
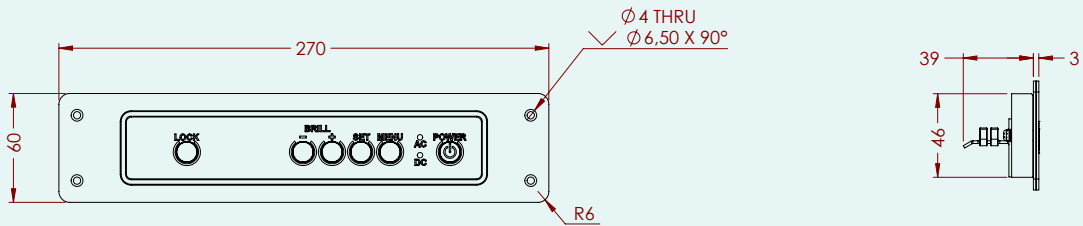

Only for use with panel mounted monitor

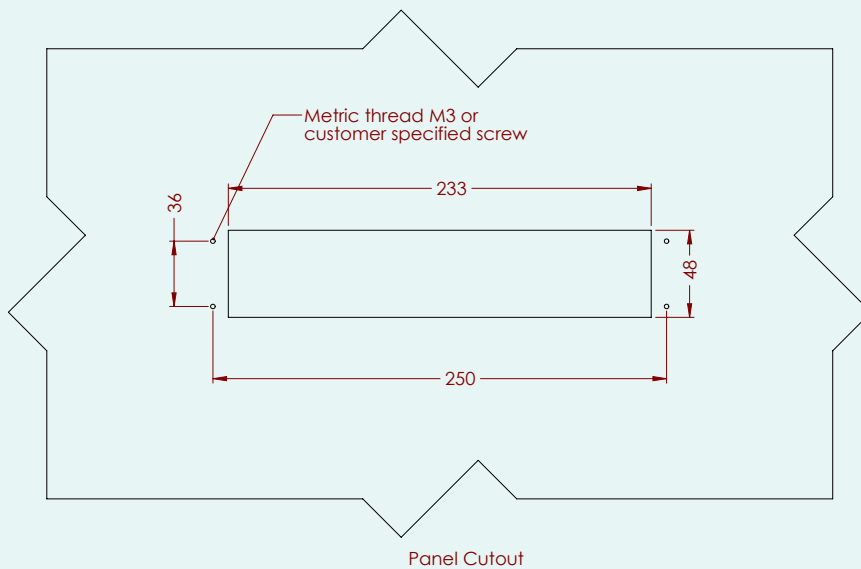
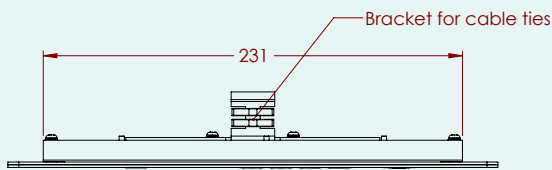



WAVE XL 46" MONITOR

WAVE XL 46" PANEL CUT OUT

Note: All dimensions are in mm.

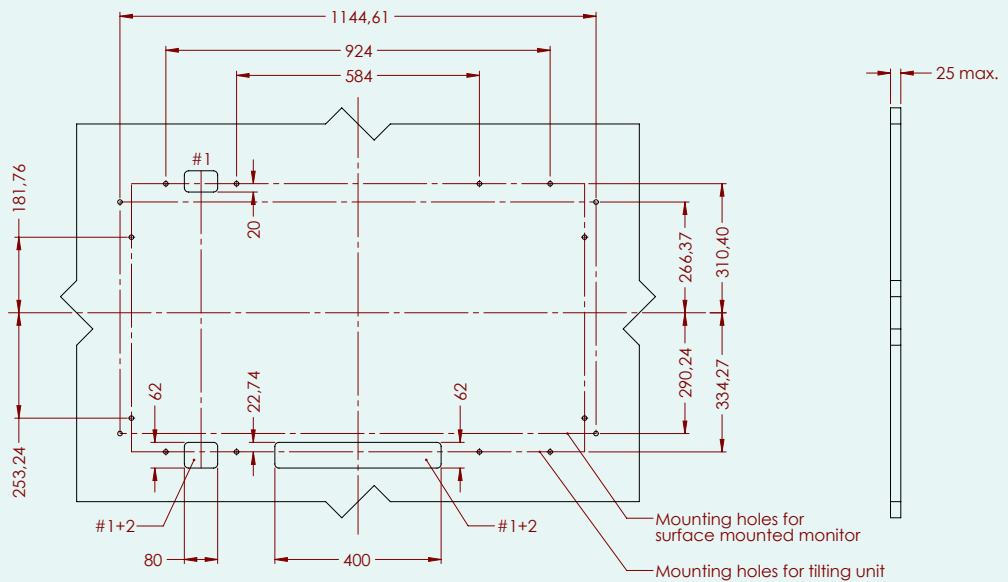
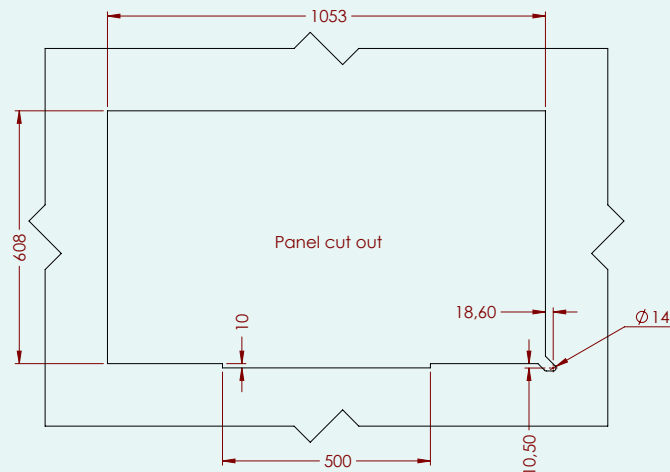

Panel cut out with surface mount and tilting unit.

- #1 Alternative holes for surface mounted monitor
- #2 Alternative holes for mounted monitor with tilting unit