

CAN Display

7" Colour LCD - C Series

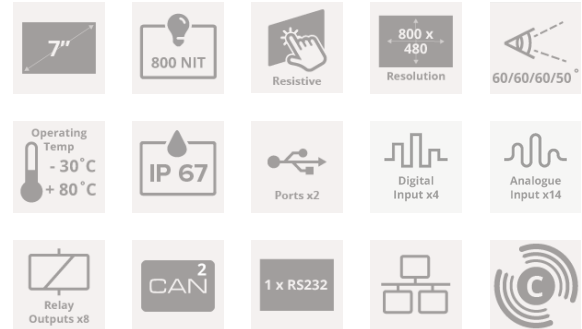

Technical Data



Introduction

It is the largest display in the range with a hi-resolution 7-inch touch-screen customisable colour display. The screen size allows developers to bring together easy to read information via a simple to operate, powerful rugged interface.

The WVGA (800x480) TFT LCD colour display can be viewed in full sunlight, has the potential for multiple screens to be displayed via user defined touch screen buttons, and supports external buttons/joystick controls. The complete unit is sealed to meet IP standards 66 (front) & 67 (rear).

It meets the need for tough, flexible instrumentation that will handle the harshest environments and where a larger display is essential. Custom applications to be rapidly created using the software development kit (SDK). The display can provide system control functions, alarm functionality, and has configurable data logging capability.

Key Features

- 2 x CANbus, 1 x RS232 Connection
- 14 x Analogue & 4 Digital Inputs
- 8 x Relay Outputs, 2 x USB Ports
- Data Logging & Control Capability
- Wi-Fi Telematics Compatible
- Ruggedised Display
- J1939/NMEA 2000/Tier 4 Support
- IP66 Front & IP67 Rear

Reliability

Our products continue to be successfully deployed in an enormously diverse range of applications where total reliability is vital.

All products, bespoke or standard range are backed up by a dedicated central team of specialist engineers able to rapidly adapt any product for a specific application and to provide an unrivalled level of customer support.

Displays are also supported with a return to base extended 24-month Manufacture warranty against mechanical failure or material defects.

Software

Our SDK is offered for a one-off licence fee from which customers can develop their own bespoke application solution. Available are optional plugins for CANopen, J1939, NMEA 2000, and support hours are included should your engineers need any help along the way.

Alternatively, we can develop bespoke software to your specification using our experienced in house engineers.

Over the years our engineers have developed software for our displays to run rock crushers & mining machinery, measure performance of spraying equipment, acting as battery monitors, boat gyro stabilisers, plus many more including military and aerospace applications.

Also available is our Engine Monitor standard software for Industrial and Marine, which can be pre-loaded to our displays receiving and displaying J1939 engine and transmission data, including common Tier4 parameters, with active alarms (from DM1) & NMEA 2000 data, where supported.

Accessories

- Cable Harnesses
- Protective Sun Covers
- Mounting Kits
- Branding - Labels & Boxes

Specifications

Hardware	
CPU	Processor is Freescale i.MX 286, running 454 MHz
Flash Memory	128 MB NAND
SDRAM	128 MB
Electrical	
Display	a-Si TFT LCD 7.0"
Resolution	800 (H) x 480 (V) WVGA
Active Area	152.40mm (H) x 91.44mm (V)
Viewing Angle	60 degrees left/right/down 50 degrees up
Number of Colours	262K
Contrast Ratio	400:1
Brightness	800 NIT (cd/m2) Fully sunlight readable
Power Requirements	10V to 32V DC
Sounder	Internal Buzzer
Connection	(3) 12 Pin Deutsch DT04-12PA Moulded in Receptacle
Communications	1 x RS232, 2 x CAN Bus 2.0B (1 isolated), 2 x USB, Ethernet
RPM Input	Magnetic Pick up or hall effect & similar with push-pull output (i.e open collector is not suitable) Maximum = 5 KHz
14 Analogue Input	Software Selectable As 0 - 2.5 VDC, 0 - 10 VDC or 0 - 1000 OHMS
3 Switch Inputs	Switch contact to ground or open collector type sensor - max. frequency = 50Hz
8 Relay/Solenoid Outputs	Open collector suitable for 0.5A continuous load
Environmental	
Operating Temperature	-30 to +80 Degrees Celsius
Storage Temperature	-40 to +80 Degrees Celsius
Degree of Protection	IP 66 Front & IP 67 Back
Mechanical	
Case Material	ABS
Case Colour	Anthracite Grey
Dimensions	205mm (W) x 157mm (H) x 30mm forward and 28mm rear (D)
Part Number	
7000	7" CAN Display
7001	7" CAN Display with Engine Monitor Software Preloaded

Dimensions

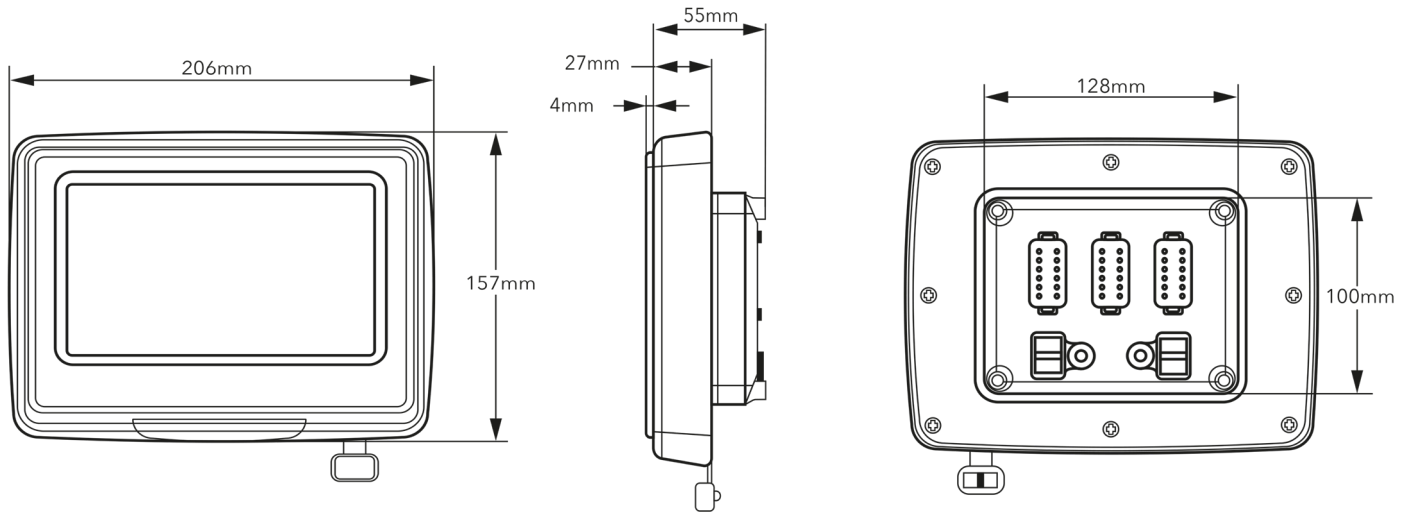

Connectors

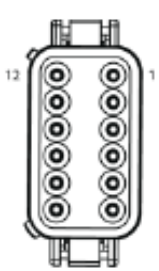
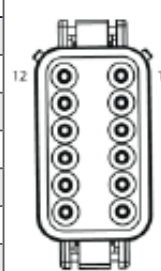
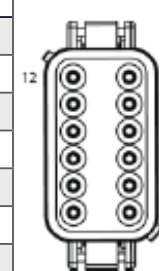
Primary			Secondary			Tertiary		
1	Ground		1	Sensor 1 Analog Input		1	Sensor 8 Analog Input	
2	Ground & Power ¹		2	Sensor 2 Analog Input		2	Sensor 9 Analog Input	
3	Relay/Solenoid Output 1		3	Sensor 3 Analog Input		3	Sensor 10 Analog Input	
4	Relay/Solenoid Output 2		4	Sensor 4 Analog Input		4	Sensor 11 Analog Input	
5	Isolated CAN Supply (-)		5	Sensor 5 Analog Input		5	Sensor 12 Analog Input	
6	Isolated CAN Supply (+)		6	Sensor 6 Analog Input		6	Sensor 13 Analog Input	
7	Isolated CAN Data H		7	Sensor 7 Analog Input		7	Sensor 14 Analog Input	
8	Isolated CAN Data L		8	Digital Input/Flow Sensor 1		8	Digital Input/Flow Sensor 3	
9	Relay/Solenoid Output 3		9	Digital Input/Flow Sensor 2		9	Relay/Solenoid Output 5	
10	Relay/Solenoid Output 4		10	Tachometer Input		10	Relay/Solenoid Output 6	
11	Primary CAN Data L		11	RS232 Receive		11	Relay/Solenoid Output 7	
12	Primary CAN Data H		12	RS232 Transmit		12	Relay/Solenoid Output 8	

Note 1. (10-32V DC) Supply should be protected by 2A – Rated circuit breaker/fuse

IMPORTANT NOTICE

Safety Warning: Please note analogue input voltages should not exceed the supply voltage or damage may occur. No power should be present on the harness during connection. USB port should not be used for charging external equipment such as mobile phones.

Connect Harness 1 (Primary) noting correct orientation of connector. Ensure it is fully mated so the connector latches into place. Then connect Harness 2 (Secondary) note correct orientation of connector. Ensure it is fully mated so the connector latches into place. Repeat with Harness 3.