

# WAVE II, 21.5" MONITOR

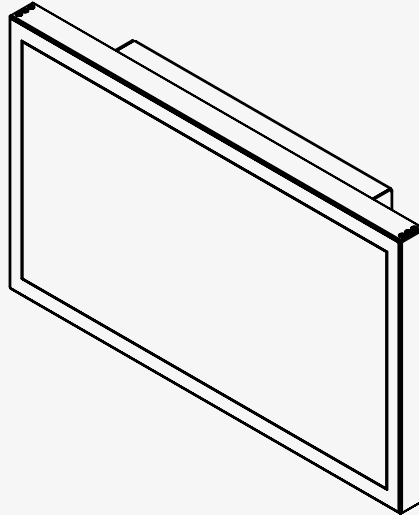

## SUMMARY

<b>ID</b>	30047	<b>NORTH INVENT PART NO</b>	WE215 000 137 (Use for ordering)
<b>COMPANY NAME</b>	North Invent Norway	<b>NORTH INVENT TYPE NO</b>	WE215-01.MON.02-0137
<b>VAT</b>	987884002VAT	<b>DRAWING REFERENCE</b>	WE215 000 137 DRW
<b>ADDRESS</b>	Sørhauggata 128		
	5527 Haugesund		
	NORWAY		

## REVISION HISTORY

APPROVED	CHECKED	DRAWN	STATUS	DESCRIPTION
2019.02.01 OKJ	2019.02.01 OKJ	2018.10.06 RNO	Issued for Use	General Update
2018.10.10 OKJ	2018.10.10 OKJ	2018.10.06 RNO	Issued for Review	Issued for Use
2018.10.06 RNO	2018.10.06 RNO	2018.10.06 RNO	Issued for Customer Review	First Revision

2018022201 2019.01.18-B1-Packing Information Added

1/4





