

13.3" PANEL COMPUTER



SUMMARY

CUSTOMER ID	30047	CPU OPTION	NORTH INVENT PART NO:
COMPANY NAME	North Invent Norway	INTEL ATOM X6413E @ 1.5 GHZ (3.0 GHZ)	WE133 000 615
VAT	987884002VAT		
ADDRESS	Sørhauggata 128 5527 Haugesund NORWAY		

NB! To order optional PSU versions and / or I/Os listed on the next page, please ask your North Invent P/N.

REVISION HISTORY

APPROVED	CHECKED	DRAWN	STATUS	DESCRIPTION
2023.09.01 OKJ	2023.09.01 OKJ	2023.09.01 OKJ	Issued for Customer Review	First Revision, illustrations to be updated
2024.19.02 NIP	2024.19.02 NIP	2024.19.02 NIP	Issued for Customer Review	General Update

13.3" PANEL COMPUTER

The North Invent 13.3" Panel Computer is a state-of-the-art computer concept, built with industrial extended temperature components.

Designed for 10 years of manufacturing, the North Invent 13.3" Panel Computer is boasting powerful 11th Generation Intel® Atom™ Processors.

It has 10 point PCAP multitouch integrated into a slim design.

As for all North Invent products the will unit remains fanless with low power consumption.



TECHNICAL SPECIFICATIONS 13.3" Panel Computer

MATCHING STANDARDS

IEC 60945, IACS E10, EMC Directive-2014/30/EU, RoHS, REACH
Compliant to a selection of MIL standards

DISPLAY SIZE	13.3" - Active area 293.47 (W) X 165.08 (H) mm
OVERALL DIMENSIONS	323,2 (W) x 201 (H) x 54,74 (D) mm
NET / GROSS WEIGHT	1.9 / 2.7 kg
RESOLUTION	Max 1920 x 1080 pixels
RESPONSE TIME	25 ms (typ)
CONTRAST RATIO	800:1 (typ)
CPU	Intel® Atom x6413E @ 1.5 GHz (3.0 GHz)
LIGHT INTENSITY	400 cd/m2 (typ)
GRAPHICS	Intel® UHD Graphics (Gen11)
VIEWING ANGLE	±89°
SSD	32GB eMMC 5.1 onboard flash
SUPPLY VOLTAGE	Wide Range 9-36 VDC
POWER CONSUMPTION	Approx. 38W
RAM	4GB 3200MT7s LPDDRx onboard memory
ENCLOSURE PROTECTION	IP 67 from front given correct mounting and sealing.
GLASS TYPE	3.0 mm Tempered, Anti Reflective
INPUT/ OUTPUT	2 x 10/100/1000 Ethernet RJ45 with TPM 2.0, 1 x DisplayPort (DP++) output, 1x USB 3.1 Gen2 Type C, 2 x USB 3.1 Gen 2 Type A, 1 x RS232 (9-pin DSUB), 1 x RS422 (9-pin DSUB).
OPERATING / STORAGE TEMPERATURE	-15/+70° C, -15/+70° C (+5/+158° F, +5/+158° F)
BACKLIGHT LIFE	Typ 50.000 Hours
DIMMING RANGE	0-100%
OS SUPPORTED	Linux and Windows
TOUCH	10 Point PCAP Multitouch

13.3" PANEL COMPUTER

TECHNICAL SPECIFICATIONS 13.3" Panel Computer

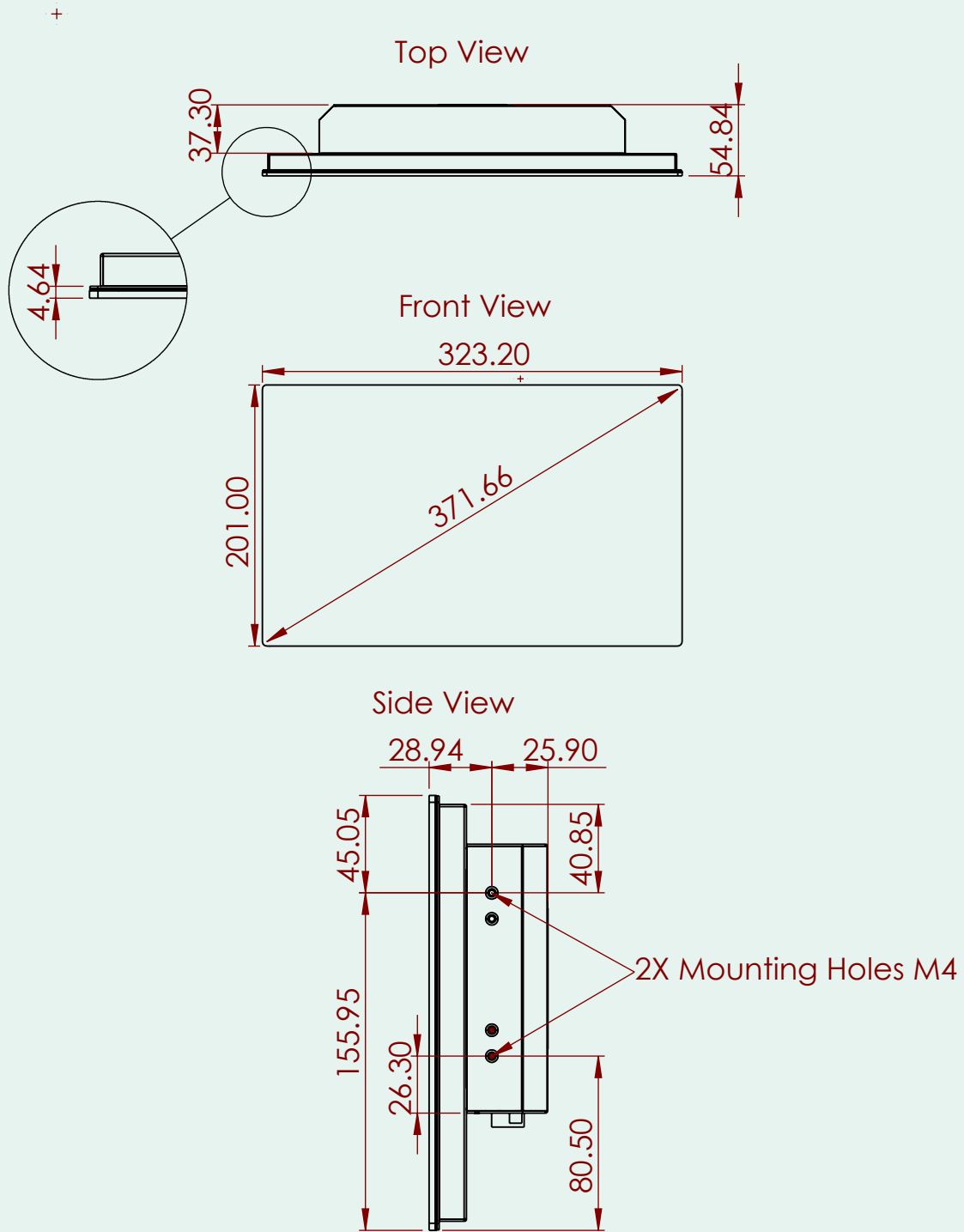

13.3" PANEL COMPUTER

TECHNICAL SPECIFICATIONS 13.3" Panel Computer

Bottom View

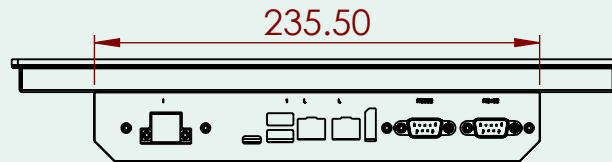

Back View

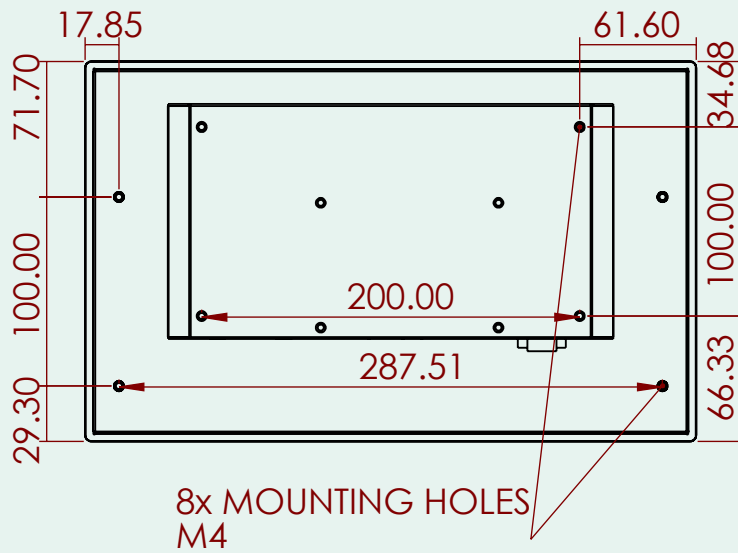

Cut out

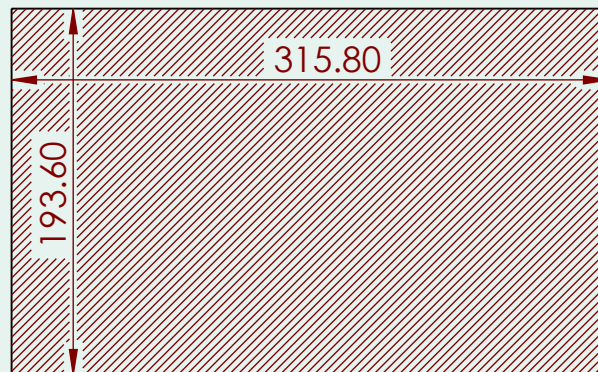

13.3" PANEL COMPUTER

TECHNICAL SPECIFICATION
13.3" Panel Computer

Mounting Brackets

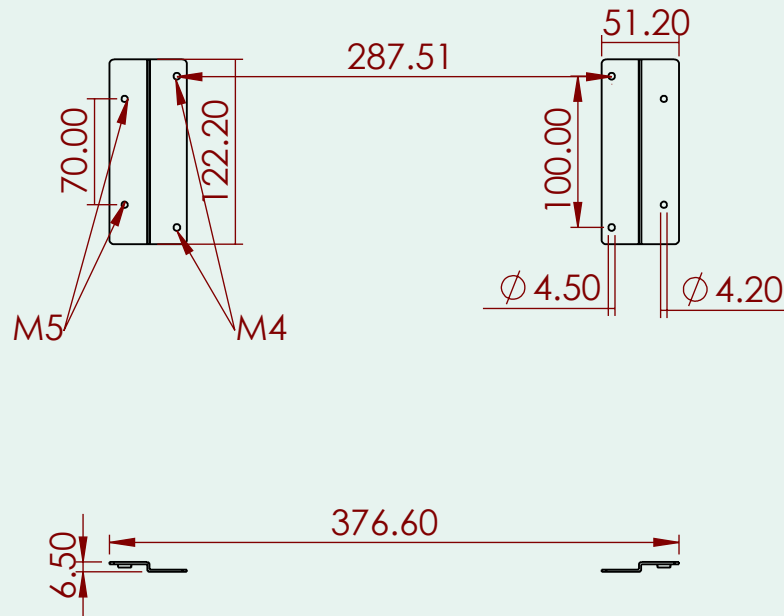
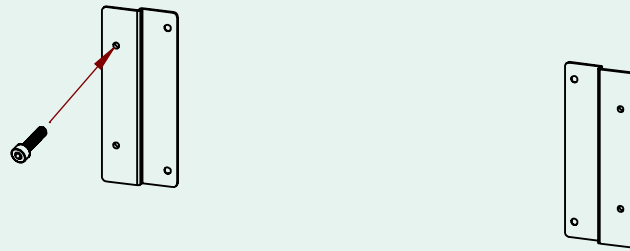

13.3" PANEL COMPUTER

TECHNICAL SPECIFICATIONS 13.3" Panel Computer

Top View

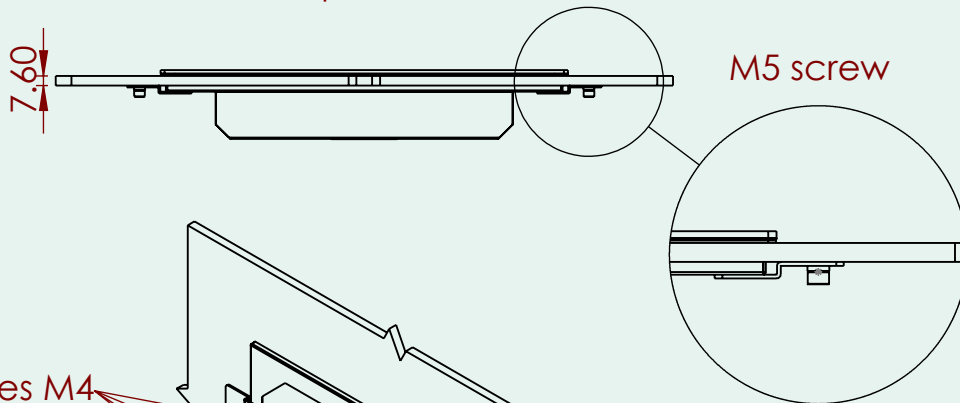

4X mounting Holes M4

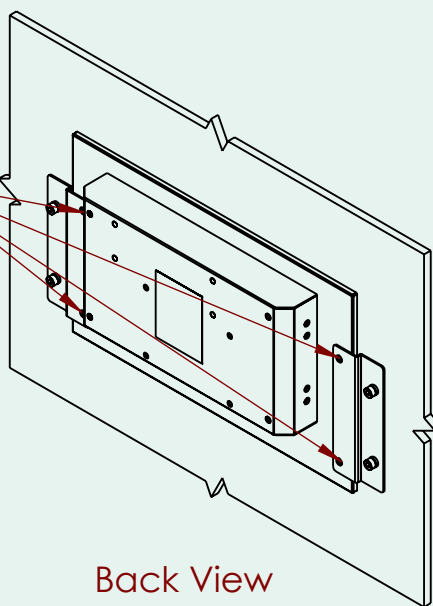

4X Mounting Holes M5

Back View

